

Engineered and manufactured gas and liquid process solutions

LECTRODRYER

adsorption technology experts since 1932

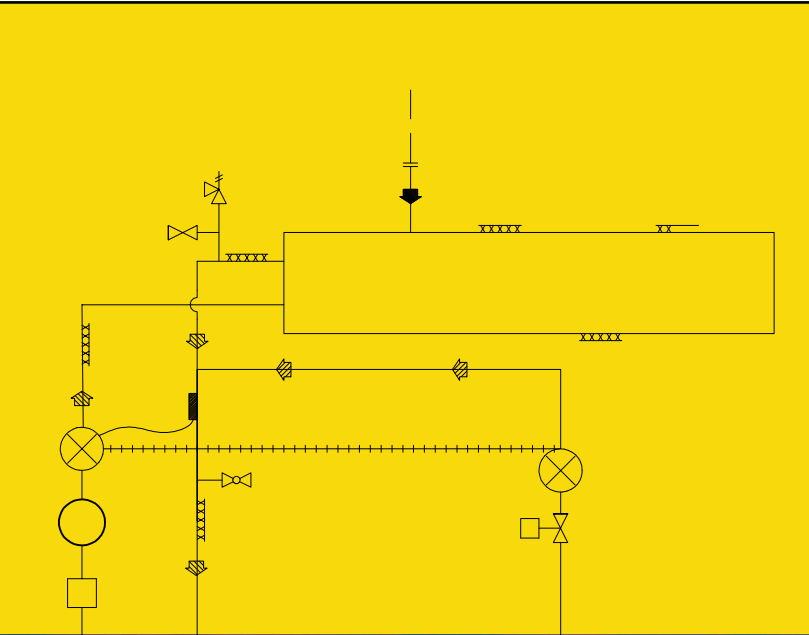

DEWPOINT APPARATUS

A simple inexpensive means for determining the moisture content of air and other non-corrosive gases at atmospheric pressure.



Lectrodryer Dewpoint Apparatus

DURABILITY

The outer container is a polished dense aluminum casting which will withstand rough handling. It is chemically inert to most gases, minimizing any corrosion problems. The observation window is a two ply safety glass which resists shattering. It is sealed in place with a special cement.

TIGHT CONSTRUCTION

The overall tight construction eliminates possible error in readings due to infiltration of atmospheric moisture. The inlet and outlet connections are integral parts of the cast outer container. The polished cup is positioned with a guide ring which insures that the cam locks on the cap will be properly engaged and the cup assembly will be locked on an "O" ring.

EASE & ACCURACY OF USE

The size and shape of the complete apparatus adds to the ease in handling. Less than a quarter turn locks the polished cup in place. The cap is funneled to minimize the boiling over of acetone. The cup is nickel plated for a long lasting, non-blemished, easily cleaned mirror surface for accurate observation.

RANGE

A dual scale dial thermometer graduated from minus 100 °C to plus 50 °C can be provided to cover the normal range of dewpoint readings.

OPERATION

1. The air or gas sample is introduced through the inlet by passing it through metal tubing. The tubing should be butted against the inlet port and held firm by slipping a rubber tubing over the connection. Caution – Do not use at pressures above 2 PSIG.
2. Pass a sample flow gas through the dewpoint apparatus. Adjust the flow to about 5 CFH. This flow can be felt when blown against wetted lips but is not readily felt by the hand.
3. Pour acetone (about 2") into the cup. Caution – acetone is flammable.
4. After the sample has passed through the apparatus for about five minutes in order to purge it completely, small amounts of crushed dry ice should be added to the acetone while stirring constantly with the thermometer.
5. At the first sign of dew or moisture on the polished surface the temperature is read from the thermometer. This reading is an accurate indication (within plus or minus 3 °C) of the dewpoint of the gas or air to be tested. The use of a mixture of acetone and dry ice in the dewpoint apparatus makes possible the checking of dewpoints as low as -76 °C. By careful practice and a little skill, Dewpoints can be checked quite closely by several different operators and the results tie in satisfactorily with more expensive gravimetric methods for the determination of the moisture content.
6. From the data chart included, the dewpoint temperature may be converted to absolute moisture content.

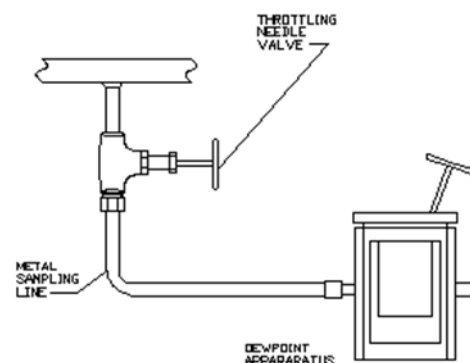

SUGGESTIONS

A reasonably bright light, preferably equipped with a shade, should be used to illuminate the polished cup so that the very first faint trace of dew can be detected. The light should be held in such a position that there will be the least glare from the polished surface.

It is suggested that the temperature of the acetone dry ice mixture should be lowered slowly in order to minimize any error due to temperature lag.

In measuring dewpoints, the surface of the polished cup should be clean and free from any grease, etc. If the surface is not clean, the appearance of the dew may not be as sharp as desired and may cause errors. The proper technique is usually gained only after some practice in making these dewpoint determinations.

When polishing the cup it is suggested that a soft optical tissue be used to prevent scratching the surface.

Dewpoint Temperature Data 14.7 P.S.I.A.

°F	Vapor Press In. HgX10 ⁻³	Gr per CF X10 ⁻²	Gr per Lb. Air X10 ⁻¹	°C
-110	.0189	.031	.028	-78.9
108	.0229	.038	.033	77.8
106	.0274	.045	.040	76.7
104	.0325	.053	.047	75.6
102	.0397	.063	.056	74.4
-100	.0461	.074	.071	-73.3
98	.0545	.087	.079	72.2
96	.0647	.103	.094	71.1
94	.0737	.121	.111	70.0
92	.0902	.142	.131	68.9
-90	.1064	.167	.155	-67.8
88	.1251	.195	.182	66.7
86	.1469	.228	.214	65.6
84	.1720	.265	.250	64.4
82	.2010	.308	.292	63.3
-80	.2347	.358	.342	-62.2
78	.2729	.414	.397	61.1
76	.3181	.480	.463	60.0
74	.3701	.556	.539	58.9
72	.4304	.643	.626	57.8
-70	.4987	.741	.726	-56.7
68	.5765	.853	.839	55.6
66	.6641	.977	.967	54.4
64	.7664	1.122	1.115	53.3
62	.8819	1.285	1.283	52.2
-60	1.014	1.470	1.476	-51.1
58	1.163	1.677	1.693	50.0
56	1.334	1.914	1.941	48.9
54	1.530	2.184	2.227	47.8
52	1.749	2.485	2.545	46.7
-50	1.999	2.826	2.909	-45.6
48	2.279	3.207	3.316	44.4
46	2.595	3.633	3.776	43.3
44	2.950	4.111	4.293	42.2
42	3.353	4.650	4.879	41.1
-40	3.803	5.250	5.535	-40.0
38	4.312	5.922	6.276	38.9
36	4.884	6.677	7.112	37.8
34	5.524	7.517	8.043	36.7
32	6.237	8.447	9.097	35.6
-30	7.010	9.449	10.206	-34.4
28	7.912	10.616	11.515	33.3
26	8.921	11.914	12.985	32.2
24	10.03	13.334	14.602	31.1
22	11.26	14.901	16.394	30.0
-20	12.62	16.625	18.375	-28.9
18	14.16	18.569	20.615	27.8
16	15.84	20.679	23.065	26.7
14	17.72	23.029	25.802	25.6
12	19.80	25.617	28.833	24.4
-10	22.10	28.466	32.186	-23.3
8	24.63	31.584	35.875	22.2
6	27.45	35.046	39.984	21.1
4	30.55	38.831	44.499	20.0
2	33.97	42.990	49.483	18.9
0	37.73	47.500	55.000	-17.8

°F	Vap. Press In. Hg	Grains per CF	Grains per Lb. Air	°C
0	.0377	.47	5.5	-17.8
2	.0418	.53	6.1	16.7
4	.0465	.58	6.7	15.6
6	.0514	.64	7.5	14.4
8	.0569	.70	8.3	13.3
+10	.0630	.78	9.2	-12.2
12	.0696	.85	10.2	11.1
14	.0777	.94	11.2	10.0
16	.0847	1.03	12.4	8.9
18	.0934	1.13	13.6	7.8
+20	.1028	1.24	15.01	-6.7
22	.1132	1.36	16.53	5.6
24	.1244	1.49	18.17	4.4
26	.1366	1.63	19.97	3.3
28	.1500	1.78	21.93	2.2
+30	.1645	1.95	24.07	-1.1
32	.1803	2.12	26.40	0.0
34	.1957	2.29	28.66	+1.1
36	.2120	2.47	31.07	2.2
38	.2292	2.66	33.62	3.3
+40	.2478	2.86	36.26	+4.4
42	.2677	3.08	39.31	5.6
44	.2891	3.32	42.48	6.7
46	.3120	3.56	45.87	7.8
48	.3364	3.83	49.50	8.9
+50	.3624	4.11	53.38	+10.0
52	.3905	4.41	57.58	11.1
54	.4200	4.72	61.99	12.2
56	.4518	5.06	66.75	13.3
58	.4854	5.42	71.82	14.4
+60	.5214	5.80	77.21	+15.6
62	.5597	6.20	83.02	16.7
64	.6004	6.62	89.18	17.8
66	.6438	7.07	95.76	18.9
68	.6900	7.57	102.8	20.0
+70	.7387	8.05	110.2	+21.1
72	.7906	8.59	118.2	22.2
74	.8455	9.15	126.6	23.3
76	.9040	9.75	135.7	24.4
78	.9658	10.38	145.3	25.6
+80	1.0316	11.04	155.5	+26.7
82	1.1013	11.75	166.4	27.8
84	1.1752	12.49	178.0	28.9
86	1.2527	13.27	190.3	30.0
88	1.3346	14.08	203.3	31.1
+90	1.4211	14.94	217.1	+32.2
92	1.5125	15.84	231.8	33.3
94	1.6088	16.79	247.5	34.4
96	1.7108	17.80	264.0	35.6
98	1.8181	18.85	281.7	36.7
+100	1.9316	19.95	300.5	+37.8
102	2.0507	21.11	320.4	38.9
104	2.1763	22.32	341.5	40.0
106	2.3084	23.60	364.0	41.1
108	2.4473	24.93	387.9	42.2
+110	2.5939	26.34	413.3	+43.3

Lectrodryer Dewpoint Apparatus - Part No. D79824
Dual Scale Stainless Steel Dial Thermometer - Part No. D53701

Replacement Cap and Cup - Part No. D79823
Replacement Body Assembly - Part No. D79822



Letrodryer

offers a complete range of drying and purification equipment for:

atmospheric or high pressure conditions • very small or very large air volumes • air, gases, and certain organic fluids

Regenerative Adsorption Dryer

Typical applications:

Drying compressed air for instruments; purging of refrigeration coils, compressors, and systems; drying air for ozone generators; vacuum-breaking operations controlled atmosphere gas

Features:

Carbon steel pressure vessels with ASME Code (where applicable) for up to 150 PSIG Stainless steel perforated metal desiccant support and inlet flow diffuser, sheathed or non sheathed heating element in which each adsorber vessel with thermostatic over temperature protection in the heater bundle, two 4-way lubricated plug valves with air piston operator and sole-noid valve controls, thermal pressure relief valves, pressure gages, dial thermometer in the purge outlet, 110 volt controls and NEMA 1 electrical enclosures.

Optional Features:

Special controls and electrical enclosures.



Refrigeration-Type Industrial Gas Dryer

Typical Application:

Low pressure situations for controlling atmospheric gases.

Features:

Power-on light, high temperature warning light, on/off switch, refrigeration analyzer gage, gas-out gage, gas-in temperature gage, low suction pressure cut-out, high head pressure cut-out, hot gas bypass capacity control, start push button pump down shut off cycle, oil pressure control, and suction accumulator.

Optional Features:

Special control and electrical enclosures.



Letrodryer Filters



The Letrodryer type SF and type F filters provide high efficiency filtration with ten sizes available in each type for flows to 8400 SCFM, larger sizes available on application. Both types have a high level filter efficiency of 99.985% retention (0.015 DOP penetration) for filtration to a 0.3 mi- cron

Lube Oil / Air Tanks



Lectrobreather tank vent dryers prevent atmospheric moisture from entering storage during "breathing" due to ambient temperature changes and draining periods.

Valuable oils and chemical solutions remain free of water contamination.



Brochure Rev.01



LECTRODRYER

135 Quality Drive
Richmond, Kentucky 40475
P.O. BOX 2500
Richmond, Kentucky
40476-2602

www.lectrodryer.com

Phone +1 (859) 624 2091
Fax +1 (859) 623 2436
USA Toll Free +1 (877) 403 5215