

Engineered and manufactured gas and liquid process solutions

LECTRODRYER

adsorption technology experts since 1932

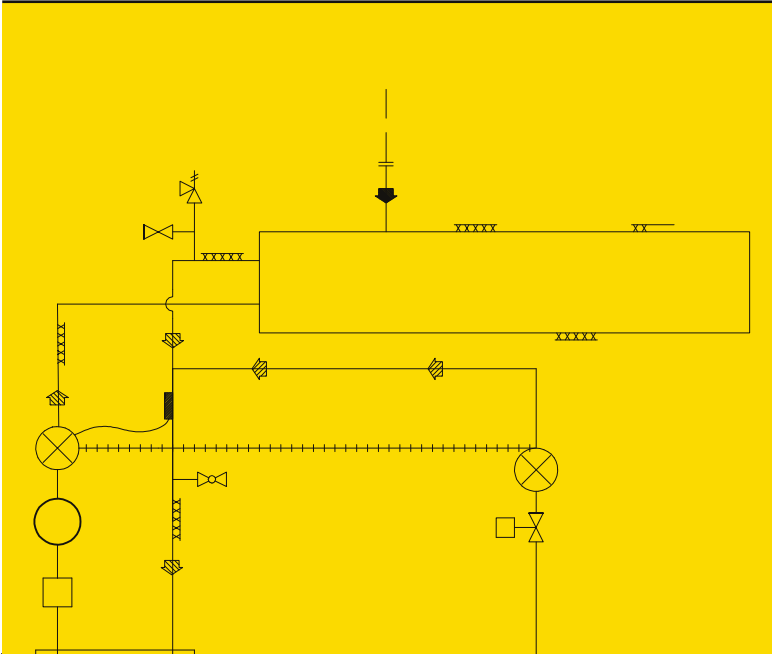

TYPE BR

Lectrobreather tank vent dryers prevent atmospheric moisture from entering storage tanks during "breathing" due to ambient temperature changes and draining periods. Valuable oils and chemical solutions remain free of water contamination.



For Safeguarding Oil and Chemicals from Moisture

Air taken into the tank passes through the Lectrobreather desiccant and is thoroughly dried. This dry air, upon leaving the tank, has a partial reactivating effect which permits long periods between reactivations. Lightly loaded inlet and outlet check valves remain closed when there is no passage of air in either direction, thus preventing "static" saturation of the desiccant with atmospheric moisture. Lectrobreaters are equipped with a color indicator for determining when the unit is in need of reactivation and when reactivation of the desiccant is complete.

Lectrobreaters mean assurance that the contents of any tank, large or small, are safe from climatic, seasonal and atmospheric moisture—that water will not contaminate the stored product, resulting in low quality, as well as increased operating costs and lower production.

Lectrobreaters are of heavy gauge carbon steel construction, satisfactory for many years of operation in the weather. Applications for storage of liquids evolving corrosive fumes, such as sulfuric acid, are handled by providing a separate stainless steel check and vent valve assembly to prevent fumes from entering the Lectrobreather.

Specifications for Lectrobreather and Reactivator

LECTROBREATHER	SIZE	BR-10	BR-50	BR-100	BR-150
A-INCHES		25	18	125	32
B-INCHES		12	20	20	20
C-INCHES		13	21	21	21
SHIPPING WEIGHT-POUNDS		80	180	250	320
TOTAL DRAIN CAPACITY-GALLONS*		10000	30000	60000	90000

REACTIVATOR	SIZE	BR-10	BR-50	BR-100	BR-150
A-INCHES		19	19	40	40
B-INCHES		22	22	26	26
C-INCHES		15	15	16	16
CONNECTED LOAD-KW		1.0	2.0	5.0	5.0
SHIPPING WEIGHT-POUNDS		140	140	220	220



Tank Vent Dryer and Reactivator

Standard electrical enclosures are NEMA-1, but NEMA-4 or NEMA-7 enclosures can be provided if desired.

Selection of the proper Lectrobreather for a specific application depends upon the size of the storage tank, the amount of material withdrawn over a given period of time, and the maximum rate of filling and draining.

The Lectrobreather is economical. Initial installation and maintenance costs are low. Pays for itself in a very short time.

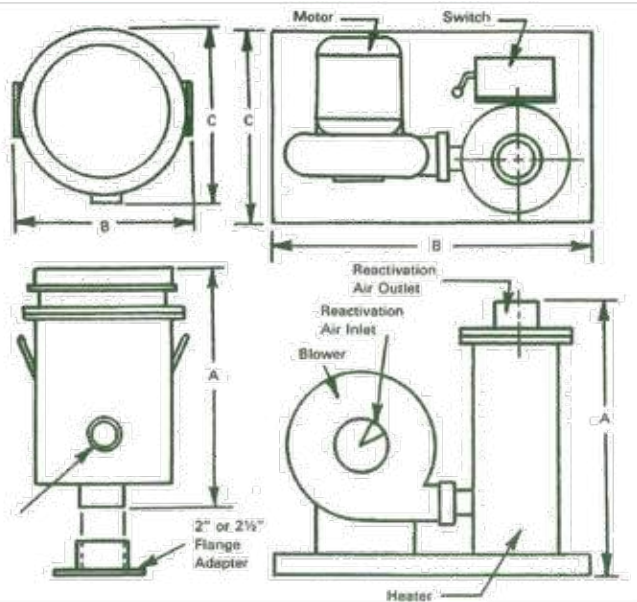

Simplification has been emphasized in the design of the Lectrobreather. A flanged adapter is provided for the storage tank vent to receive the Lectrobreather, which then seals itself on a soft gasket by virtue of its own weight. Removal for reactivation requires merely lifting and placing on a similar adapter on the reactivator. Fool-proof operation is assured with a minimum of maintenance.

The separately mounted reactivator can be centrally located to serve one or more Lectrobreaters. The reactivator consists of a sheathed type electric heater with thermostatic over-temperature protection and a motor driven blower to provide the proper quantity of heated air.

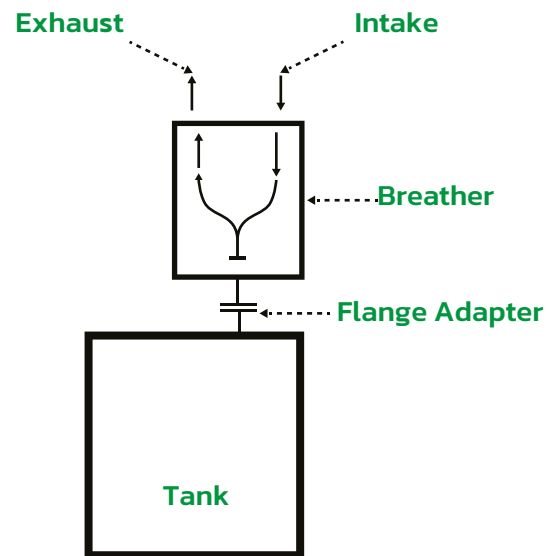

It is suggested that the Breather be mounted directly on tank when material is non-corrosive.

Stainless Steel Vent Valve

The Lectrodryer Stainless Steel Vent Valve Assembly is used in cases where corrosive or toxic fumes are present and should be used with the Lectrobreather (BR). All intake air passes through the Lectrobreather and all exhaust air is expelled without passing through the Lectrobreather. This prevents desiccant contamination and the expulsion of toxic vapors during reactivation.

The Vent Valve is constructed of 316L Stainless Steel materials.



LECTRODRYER offers a complete range of drying and purification equipment:

- * For atmospheric or high pressure conditions
- * For very small or very large volumes
- * For air, gases, liquids and certain organic fluids
- * Completely packaged systems
- * Custom engineered and manufactured

Regenerative Adsorption Dryer

Typical applications:

Drying compressed air for instruments; purging of refrigeration coils, compressors, and systems; drying air for ozone generators; vacuum-breaking operations controlled atmosphere gas

Features:

Carbon steel pressure vessels with ASME Code (where applicable) for up to 150 PSIG Stainless steel perforated metal desiccant support and inlet flow diffuser, sheathed or non sheathed heating element in which each adsorber vessel with thermostatic over temperature protection in the heater bundle, two 4-way lubricated plug valves with air piston operator and sole-noid valve controls, thermal pressure relief valves, pressure gages, dial thermometer in the purge outlet, 110 volt controls and NEMA 1 electrical enclosures.

Optional Features:

Special controls and electrical enclosures.



Refrigeration-Type Industrial Gas Dryer

Typical Application:

Low pressure situations for controlling atmospheric gases.

Features:

Power-on light, high temperature warning light, on/off switch, refrigeration analyzer gage, gas-out gage, gas-in temperature gage, low suction pressure cut-out, high head pressure cut-out, hot gas bypass capacity control, start push button pump down shut off cycle, oil pressure control, and suction accumulator.

Optional Features:

Special control and electrical enclosures.



Lectrodryer Filters



The Lectrodryer type SF and type F filters provide high efficiency filtration with ten sizes available in each type for flows to 8400 SCFM, larger sizes available on application. Both types have a high level filter

Lube Oil / Air Tanks



Lectrobreather tank vent dryers prevent atmospheric moisture from entering storage during "breathing" due to ambient temperature changes and draining periods.



Brochure Rev. 01



LECTRODRYER

135 Quality Drive
Richmond, Kentucky 40475
P.O. BOX 2500
Richmond, Kentucky
40476-2602

www.lectrodryer.com

Phone +1 (859) 624 2091
Fax +1 (859) 623 2436
USA Toll Free +1 (877) 403 5215

