



LECTRODRYER

ADSORPTION TECHNOLOGY EXPERTS

LANDFILL GAS COMPRESSION SYSTEM



EAST KENTUCKY POWER PENDELTON COUNTY LANDFILL GAS-TO-ENERGY PROJECT FALMOUTH, KENTUCKY



LANDFILL GAS COMPRESSION SYSTEM

SYSTEM DESCRIPTION

The Lectrodryer Landfill Gas Compression System is designed to compress, clean, and deliver a volume of landfill gas at a specified pressure and quality. The LGCS strives for efficiency, one that minimizes initial cost and seeks to operate at the lower possible horsepower. Lectrodryer's Landfill Gas Compression System is designed to meet customer specifications and can be installed indoors or outdoors.

COMPONENTS

The Landfill Gas Compression and Clean-up System consists of:

- Blower
- Electric Motors
- Oil Management System
- Automatic Suction Valve
- Suction Liquid Knockout Vessel
- Aftercooler
- Discharge Coalescing Gas Filter
- Scrubber
- Gas Reheat Exchanger
- Controls

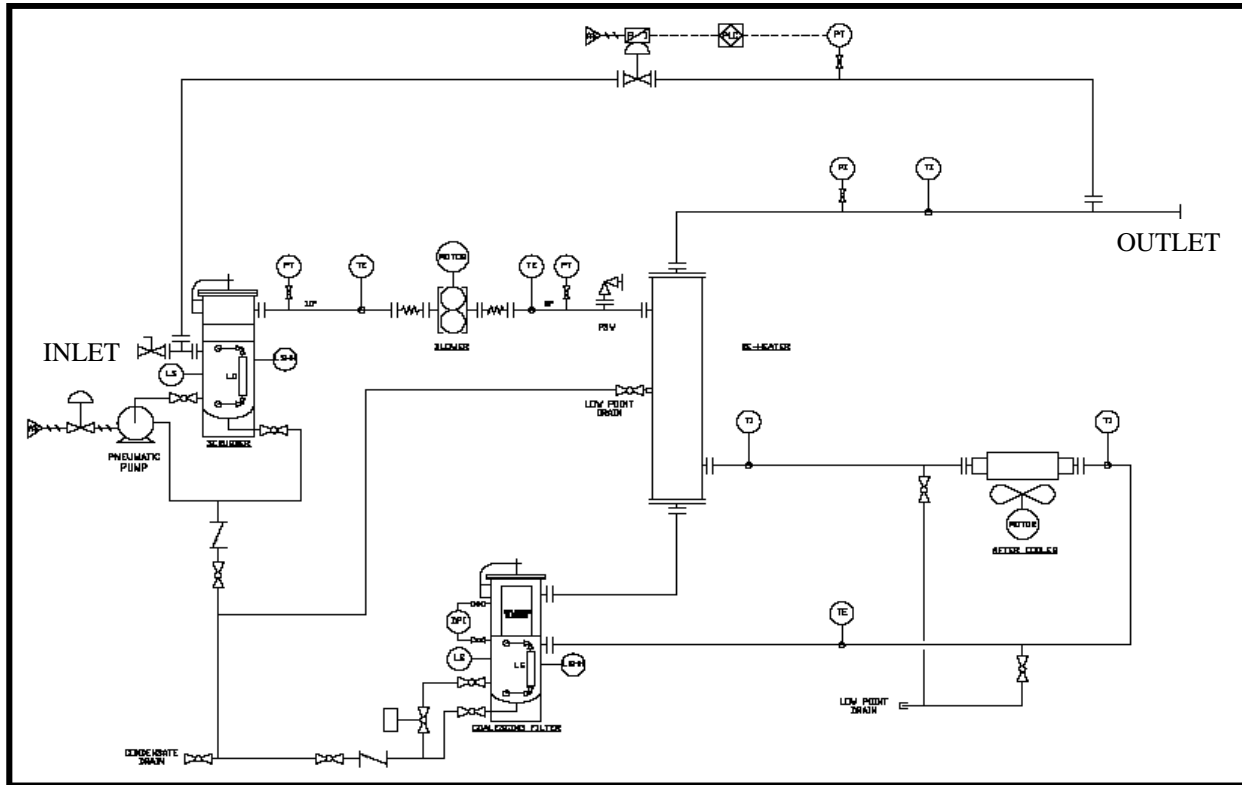

CONTINUING THE TRADITION OF QUALITY AND SERVICE SINCE 1932

LECTRODRYER

P.O. Box 2500, Richmond, KY 40476-2602 U.S.A.
Phone: (859) 624-2091 Fax: (859) 623-2436
Website: www.lectrodryer.com E-mail: info@lectrodryer.com