



HPB Series High Pressure Desiccant Dryer

Simply the most efficient and dependable high pressure desiccant dryer available.

Units are capable of handling pressures ranging from 500 PSIG to 6000 PSIG.

Dryers are available with fully automatic PLC controls or manual controls. Dryers are capable of producing dewpoints of -80°F and below.

FEATURES:

- Internal heater design minimizes costly purge losses
- Solid state heater control and over-temperature protection
- Stainless steel desiccant screens
- Allen-Bradley PLC control with operator interface panel
- Purge flow meter for accurate reactivation flow adjustments
- Tower pressure indicators
- Tower pressure relief valves
- High performance stainless steel ball type switching valves
- Depressurization valve designed to control noise and reduce desiccant attrition

OPTIONAL

- Tower temperature gauges
- Tower temperature switches
- Inlet and outlet pressure gauges



ITEM	QTY	DESCRIPTION
ADS-1,2	2	Adsorber Vessel
HRT-1,2	2	Electric Heater
V-1,2,3,4,5,6	6	Automated Ball Valve
CV-1,2	2	Check Valve
DV-1	1	Depressurization Valve
FM-1	1	Flow Meter
PI-1,2	2	Pressure Indicator
PSV-1,2	2	Pressure Safety Valve
TIS-1,2	2	Temperature Indicating Switch
V-7,8,9	3	Needle Valve
V-10,11	2	Manual Block Valve
MF-1,2	2	Reactivation Muffler

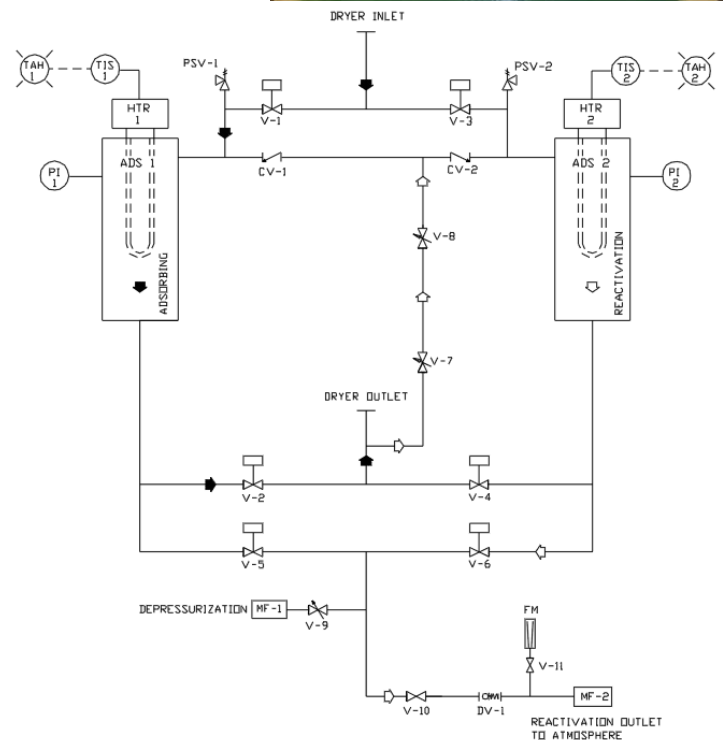

HPB FLOW SCHEMATIC

LECTRODRYER HAS THE SOLUTION FOR ALL COMPRESSED AIR AND GAS DRYING PROBLEMS

Lectrodryer offers a complete range of drying and purification equipment:
For atmospheric or high pressure conditions
For very small or very large air volumes
For air, gases, and certain organic fluids

Regenerative Adsorption Dryer

Typical applications:

Drying compressed air for instruments; purging of refrigeration coils, compressors, and systems; drying air for ozone generators; vacuum-breaking operations controlled atmosphere gas



Features:

Carbon steel pressure vessels with ASME Code (where applicable) for up to 150 PSIG Stainless steel perforated metal desiccant support and inlet flow diffuser, sheathed or non sheathed heating element in which each adsorber vessel with thermostatic over temperature protection in the heater bundle, two 4-way lubricated plug valves with air piston operator and solenoid valve controls, thermal pressure relief valves, pressure gages, dial thermometer in the purge outlet, 110 volt controls and NEMA 1 electrical enclosures.

Optional Features:

Special controls and electrical enclosures.

Refrigeration-Type Industrial Gas Dryer

Typical Application:

Low pressure situations for controlling atmospheric gases.



Features:

Power-on light, high temperature warning light, on/off switch, refrigeration analyzer gage, gas-out gage, gas-in temperature gage, low suction pressure cut-out, high head pressure cut-out, hot gas bypass capacity control, start push button pump down shut off cycle, oil pressure control, and suction accumulator.

Optional Features:

Special control and electrical enclosures.

Lectrodryer Filters

The Lectrodryer type SF and type F filters provide high efficiency filtration with ten sizes available in each type for flows to 8400 SCFM, larger sizes available on application. Both types have a high level filter efficiency of 99.985% retention (0.015 DOP penetration) for filtration to a 0.3 micron



Lube Oil / Air Tanks

Lectrobreather tank vent dryers prevent atmospheric moisture from entering storage during "breathing" due to ambient temperature changes and draining periods. Valuable oils and chemical solutions remain free of water contamination.



CRN



IECEX

ASME

SQL



CONTINUING THE TRADITION OF QUALITY AND SERVICE SINCE 1932

LECTRODRYER

P.O. Box 2500, Richmond, KY 40476-2602 U.S.A.
Phone: (859) 624-2091 Fax: (859) 623-2436
Website: www.lectrodryer.com E-mail: info@lectrodryer.com