

# LECTRODRYER

ADSORPTION TECHNOLOGY EXPERTS



## TYPE BP

COMPRESSED AIR AND GAS DRYER



# TYPE BP OFFERS CLOSED CIRCUIT REACTIVATION AT LINE PRESSURE

The Type BP has a closed-circuit reactivation system that makes it ideal for drying gases without life contamination from the atmosphere. And this includes typical gases such as hydrogen, nitrogen, helium, argon, and methane. The BP accomplishes this by using dual adsorbers that are heat reactivated for drying compressed air and other gases to dewpoints down to -80°F, with reactivation occurring at line pressure.

The closed-circuit reactivation system consists of a re-circulating blower, external heater, water-cooled inner cooler, moisture separator, condensate trap. Line pressure reactivation eliminates the need for depressurizing for switchover. By eliminating these operations, the BP prevents the possibility of bed-pressure shocks which can contribute to desiccant failure, dusting, high bed-pressure drop,

rupture of bed screens, abnormally short desiccant life. With equalized pressure on both towers on adsorption and reactivation, the BP experiences no cross leakage on the four-way valves. And because the reactivation blower is designed for operating at the system's line pressure, horsepower requirements are much less than for units with low pressure.

The BP Lectrodryer is available for electric or steam reactivation in standard or steam reactivation in standard sizes ranging from 200 SCFM to 20,000 SCFM. And depending on the application, the desiccants can be either activated alumina, silica gel, sorbead, or a molecular sieve.

## TYPICAL SPECIFICATIONS

Model	Length	Width	Height	Weight/ Lbs.	Connected Load/KVA	Average KW	Steam Reactivation lbs/hr Average	Cooling Water/ GPM	Standard Connections	Blower HP
BP-225	57"	30"	90"	1,100	4.5	3.3	15	1-1/2	1-1/2"	1-1/2
BP-325	69"	35"	90"	1,600	7.5	5.6	22	2	1-1/2"	2
BP-600	82"	42"	130"	3,000	15	11.2	41	3-1/2	2"	2
BP-1000	72"	48"	130"	5,000	24	18	70	5-1/2	2" or 3"	3
BP-1500	72"	50"	120"	7,700	40	30	104	8-1/2	3"	3
BP-2000	134"	60"	120"	9,900	50	37.5	139	11	3" or 4"	5
BP-3000	134"	70"	106"	15,000	70	52.5	210	16	4" or 6"	5
BP-4000	137"	75"	115"	19,000	100	75	278	23	6"	7-1/2
BP-5000	148"	75"	118"	24,000	120	90	345	29	6"	7-1/2
BP-6500	140"	80"	130"	32,000	150	112	450	38	6" or 8"	10
BP-8000	152"	85"	130"	39,000	190	142	553	45	8"	10
BP-12000	178"	100"	140"	60,000	280	210	829	68	8" or 10"	15
BP-20000	204"	112"	140"	80,000	460	345	1,384	113	10"	15

1. Steam consumption is based on 150 psig saturated steam
2. Utility requirements are based on a full load condition
3. Utility requirements may be reduced by utilizing the Reactivation Termination and Lectrolod Demand Cycle Control options.



# Flow Diagram for the Type BP Lectrodryer

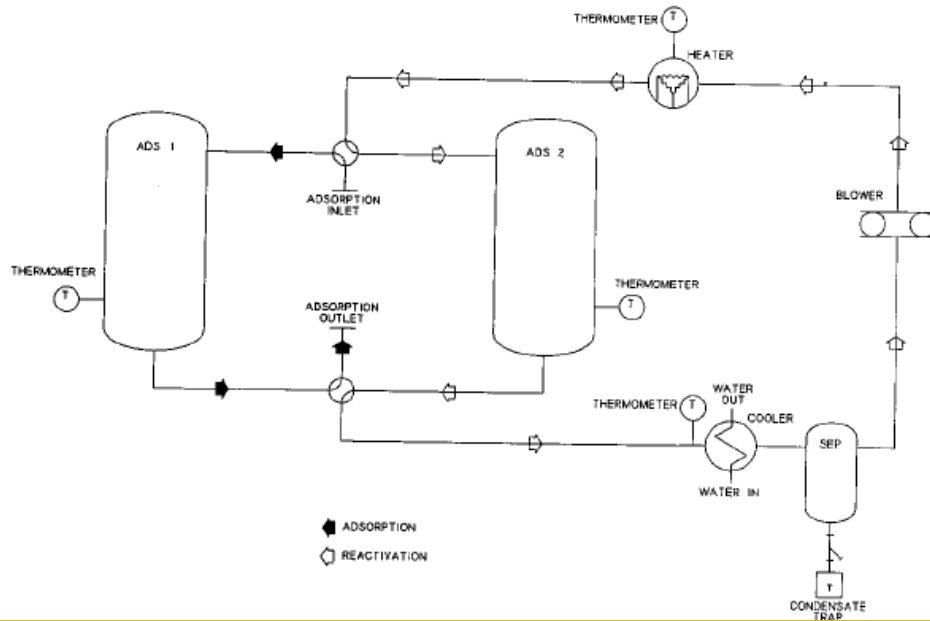

## This is How the Type-BP works

### Automatic Operation

The type BP is a fully automatic unit supplying a continuous flow of dry air or gas. It requires very little maintenance, except for occasional lubrication.

The Type BP Lectrodryer runs on an eight-hour NEMA cycle with four hours on adsorption, three hours on heating, and one hour on cooling. The reactivation circuit is designed for 100% reactivation of the desiccant under any operating conditions to complete saturation of the desiccant bed. During periods of light loading, the reactivation heating will be terminated as soon as the bed has been reactivated. The one-hour cooling period assures that the desiccant bed will be cooled down before switching to the drying service, eliminating both the high temperature and possible unacceptable dewpoint for a period of time at switchover.

### Controls

- The operating period is controlled by an adjustable timer.
- Cycle indicating lights give the status of the dryer.
- Steam flow is controlled by a valve providing reliable, positive closing at high temperatures.
- A thermostat is provided for protection of electric heaters.

### Instrumentation

All Type BP Lectrodryers are equipped with tower pressure gages with thermometers indicating input and output reactivation temperatures, and indicating lights for reactivation.

### Standard Features

- Two 4-way lubricated plug valves
- Desiccant drain and fill connections with manways as required.
- Stainless steel desiccant support screens.
- Thermometers
- Thermostat for over-heat protection
- Thermal relief valves, indicating lights, and heat contactor
- Tower pressure gages, cycle timer, and motor starter
- NEMA-1 electrical enclosures

### Optional Features

- Non-lubricated valves
- NEMA 4, 12, and 7 electrical enclosures
- Switch failure alarm
- Heater failure alarm
- High-temperature alarm
- High-humidity alarm
- Lectrolod demand cycle control



# LECTRODRYER HAS THE SOLUTION FOR ALL COMPRESSED AIR AND GAS DRYING PROBLEMS

**Lectrodryer offers a complete range of drying and purification equipment:**  
**For atmospheric or high pressure conditions**  
**For very small or very large air volumes**  
**For air, gases, and certain organic fluids**

## Regenerative Adsorption Dryer

### Typical applications:

Drying compressed air for instruments; purging of refrigeration coils, compressors, and systems; drying air for ozone generators; vacuum-breaking operations controlled atmosphere gas



### Features:

Carbon steel pressure vessels with ASME Code (where applicable) for up to 150 PSIG Stainless steel perforated metal desiccant support and inlet flow diffuser, sheathed or non sheathed heating element in which each adsorber vessel with thermostatic over temperature protection in the heater bundle, two 4-way lubricated plug valves with air piston operator and solenoid valve controls, thermal pressure relief valves, pressure gages, dial thermometer in the purge outlet, 110 volt controls and NEMA 1 electrical enclosures.

### Optional Features:

Special controls and electrical enclosures.

## Refrigeration-Type Industrial Gas Dryer

### Typical Application:

Low pressure situations for controlling atmospheric gases.



### Features:

Power-on light, high temperature warning light, on/off switch, refrigeration analyzer gage, gas-out gage, gas-in temperature gage, low suction pressure cut-out, high head pressure cut-out, hot gas bypass capacity control, start push button pump down shut off cycle, oil pressure control, and suction accumulator.

### Optional Features:

Special control and electrical enclosures.

## Lectrodryer Filters

The Lectrodryer type SF and type F filters provide high efficiency filtration with ten sizes available in each type for flows to 8400 SCFM, larger sizes available on application. Both types have a high level filter efficiency of 99.985% retention (0.015 DOP penetration) for filtration to a 0.3 micron



## Lube Oil / Air Tanks

Lectrobreather tank vent dryers prevent atmospheric moisture from entering storage during "breathing" due to ambient temperature changes and draining periods. Valuable oils and chemical solutions remain free of water contamination.



CONTINUING THE TRADITION OF QUALITY AND SERVICE SINCE 1932

# LECTRODRYER

P.O. Box 2500, Richmond, KY 40476-2602 U.S.A.  
Phone: (859) 624-2091 Fax: (859) 623-2436  
Website: [www.lectrodryer.com](http://www.lectrodryer.com) E-mail: [info@lectrodryer.com](mailto:info@lectrodryer.com)