

LECTRODRYER

ADSORPTION TECHNOLOGY EXPERTS



TYPE B PROCESS GAS DRYERS



TYPE B LECTRODRYER FOR PROCESS GAS PURIFICATION

The Type B Lectrodryer are designed to remove water and other impurities from process gases down to 0.1ppm. Problems in a process which may arise from hazardous or corrosive contaminants in the process gas stream can be easily and effectively remedied with this B-type Lectrodryer.

The B-Type dryers are single or dual tower units designed for continuous or intermittent drying of process gases to very low outlet water concentrations. Removal of water or contaminants is accomplished by adsorption to a desiccant. The desiccant is then reactivated for continued use.

A large range of standard sizes, with a variety of reactivation circuits are offered. Lectrodryer will determine which size and type of reactivation is best for each individual application and will custom design units to fit any specific drying need.

FEATURES

The standard Type B Lectrodryer features include carbon steel pressure vessels with ASME Code stamping for pressures up to 6000 psig, stainless steel

perforated metal desiccant supports, desiccant fill and drain nozzles, individually operated straightway valves for tower switching, thermal relief valves, pressure and temperature gages, reactivation package and either manual, semi-automatic or fully automatic operation with NEMA 1, 4, 12, or 7 electrical enclosures.

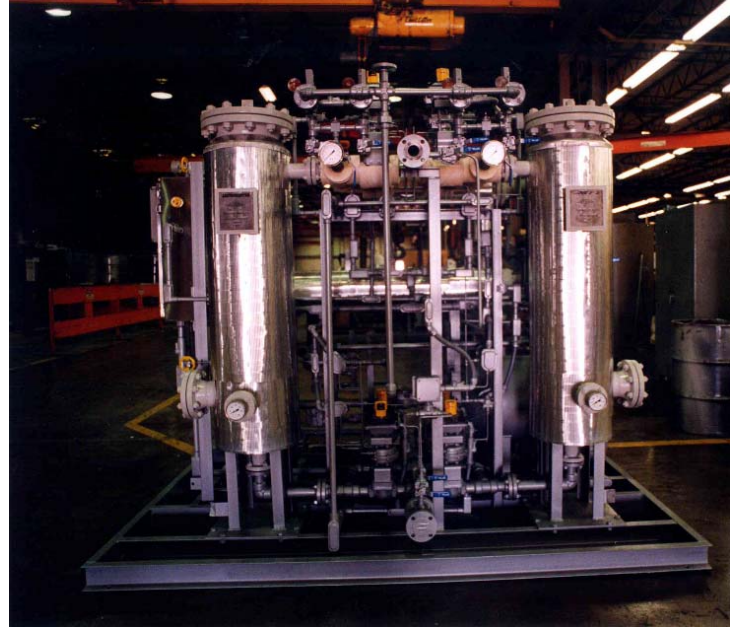

TYPE B TYPICAL SPECIFICATIONS

Model	Length	Width	Height	Weight (lbs.)	Electric Reactivation Connected Load/KVA
B-225	60	28	75	1250	4.5
B-325	70	35	75	1750	7.5
B-600	75	35	110	3000	15
B-1000	75	40	110	4750	24
B-1500	80	48	120	7800	40
B-2000	130	60	120	9100	50
B-3000	134	60	125	14250	70
B-4000	137	65	125	17800	100
B-5000	140	67	128	22100	120
B-6500	140	70	128	31200	150
B-8000	150	80	130	36800	190
B-12000	180	110	140	52000	280
B-20000	214	140	142	61000	460



TYPICAL B REACTIVATION ALTERNATIVES

A variety of reactivation circuits are available with the B-Type Lectrodryers. Open or closed circuit regeneration is available, as well as co-current or countercurrent heating and cooling. Regeneration can be accomplished by electric or steam, or a combination of the two. Lectrodryer engineers will work with you to determine the reactivation scheme best suited for your application.

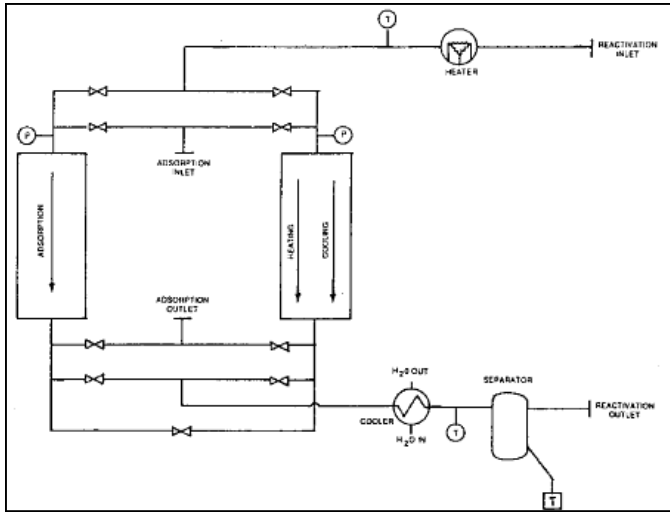

- Closed Circuit Regeneration
- Conservation of Regeneration Gas
- Cocurrent or countercurrent heating and cooling

- Purge Gas regeneration
- Cocurrent or countercurrent heating and cooling

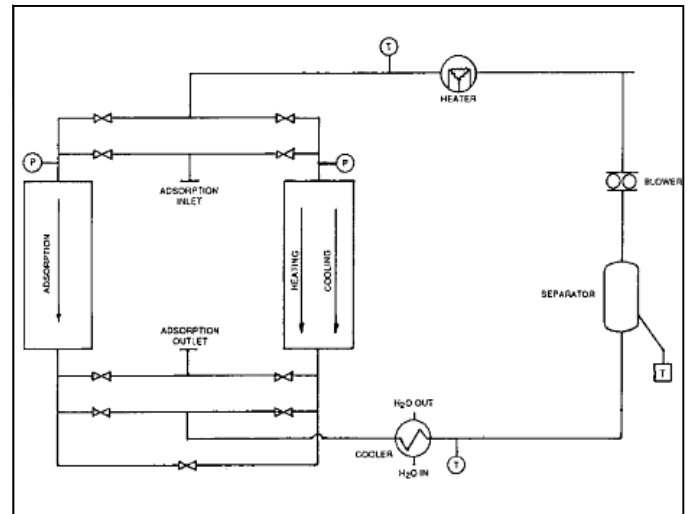

- Purge Gas regeneration
- Cocurrent or countercurrent heating and cooling
- Conservation of Regeneration Gas

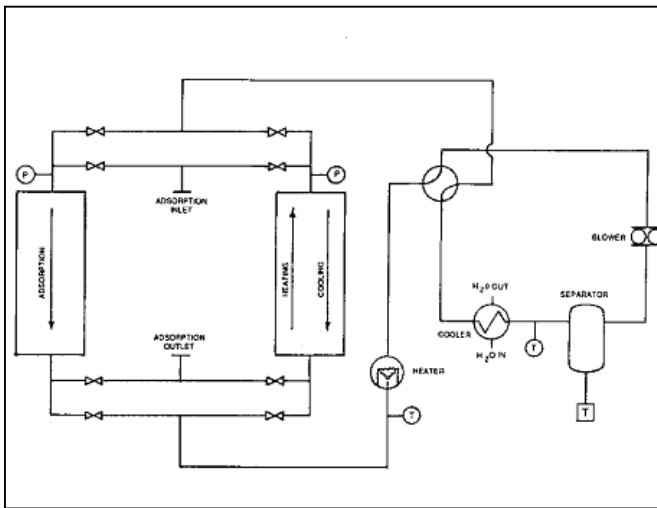

LECTRODRYER HAS THE SOLUTION FOR ALL COMPRESSED AIR AND GAS DRYING PROBLEMS

Lectrodryer offers a complete range of drying and purification equipment:
For atmospheric or high pressure conditions
For very small or very large air volumes
For air, gases, and certain organic fluids

Regenerative Adsorption Dryer

Typical applications:

Drying compressed air for instruments; purging of refrigeration coils, compressors, and systems; drying air for ozone generators; vacuum-breaking operations controlled atmosphere gas



Features:

Carbon steel pressure vessels with ASME Code (where applicable) for up to 150 PSIG Stainless steel perforated metal desiccant support and inlet flow diffuser, sheathed or non sheathed heating element in which each adsorber vessel with thermostatic over temperature protection in the heater bundle, two 4-way lubricated plug valves with air piston operator and solenoid valve controls, thermal pressure relief valves, pressure gages, dial thermometer in the purge outlet, 110 volt controls and NEMA 1 electrical enclosures.

Optional Features:

Special controls and electrical enclosures.

Refrigeration-Type Industrial Gas Dryer

Typical Application:

Low pressure situations for controlling atmospheric gases.



Features:

Power-on light, high temperature warning light, on/off switch, refrigeration analyzer gage, gas-out gage, gas-in temperature gage, low suction pressure cut-out, high head pressure cut-out, hot gas bypass capacity control, start push button pump down shut off cycle, oil pressure control, and suction accumulator.

Optional Features:

Special control and electrical enclosures.

Lectrodryer Filters

The Lectrodryer type SF and type F filters provide high efficiency filtration with ten sizes available in each type for flows to 8400 SCFM, larger sizes available on application. Both types have a high level filter efficiency of 99.985% retention (0.015 DOP penetration) for filtration to a 0.3 micron



Lube Oil / Air Tanks

Lectrobreather tank vent dryers prevent atmospheric moisture from entering storage during "breathing" due to ambient temperature changes and draining periods. Valuable oils and chemical solutions remain free of water contamination.



CRN



IECEX

ASME

SQL



CONTINUING THE TRADITION OF QUALITY AND SERVICE SINCE 1932

LECTRODRYER

P.O. Box 2500, Richmond, KY 40476-2602 U.S.A.
Phone: (859) 624-2091 Fax: (859) 623-2436
Website: www.lectrodryer.com E-mail: info@lectrodryer.com