

LECTRODRYER

ADSORPTION TECHNOLOGY EXPERTS



AIR-TYPE Lectrodryers



AIR-TYPE LECTRODRYERS

Simple, dependable adsorption drying

The AIR line of Lectrodryers is a series of dryers designed specifically for general plant and instrument air service. These dryers were developed to be low in first cost, low in cost operation, and require little attention or maintenance. This was accomplished by making each unit as simple and foolproof as possible.

Each AIR model is a dual tower, solid adsorption, heat reactivated air dryer. With these dual tower units, one column does the drying job as compressed air passes through it. Then the drying function is switched to the other column, while the first is dried or reactivated. This cycling is fully automatic and continuous so that no manual attention is required for switching adsorber columns. Positively driven 4-way valves reverse the adsorbers on a time cycle. A simple, adjustable timer may be field-set to provide extra flexibility, adjusting the heating and cooling periods to the optimum

time for load requirements. Other than the valves and the timer, there are no moving parts, nothing to require adjustment or get out of order. Drying is accomplished with ball activated alumina. The alumina has great physical strength resistance to high temperatures, ease of reactivation, thorough drying qualities and impervious to free water, making it well suited for this equipment.

AIR type Lectrodryers provide air with a dewpoint of -40°F and below. This is far below the dewpoint of the common chemical dryers or refrigerant type dryers. This dry air may be piped throughout your system without danger of condensing in your piping, equipment or controls.

AIR type Lectrodryers are available in a full range of sizes and capacities. There is a size that is right for your operation.

TYPICAL SPECIFICATIONS*

MODEL	LENGTH	WIDTH	HEIGHT	WEIGHT	HEATER (KW)	PURGE (SCFM)	CONNECTIONS	
AIR-4	24"	8"	32"	100#	.45	110/1/60	3/8"	
AIR-8	24"	12"	32"	160#	.90		3/8"	
AIR-9	48"	22"	57"	500#	1.0		1"	
AIR-15	52"	22"	57"	700#	1.4	440/3/60	1"	
AIR-25	52"	22"	77"	850#	2.2		3.0	1"
AIR-35	52"	24"	62"	950#	3.0		4.0	1½"
AIR-45	52"	24"	75"	1,200#	4.0		5.5	1½"
AIR-55	54"	28"	70"	1,400#	4.5		6.5	1½"
AIR-70	54"	28"	85"	1,600#	5.0		8.5	1½"
AIR-90	60"	30"	72"	2,000#	8.0		11.0	2"
AIR-120	60"	30"	90"	2,500#	10.0		15.0	2"
AIR-150	68"	30"	91"	3,000#	14.0		18.0	2"
AIR-200	78"	40"	75"	4,500#	18.0		24.0	3"
AIR-260	78"	40"	90"	5,500#	24.0	37.0	3"	

*SUBJECT TO CHANGE WITHOUT NOTICE

FEATURES

Wall Mounted: Models AIR-4 and AIR-8

Standard features for the wall mounted Lectrodryer include adsorber vessels built for working pressure up to 150 PSIG, with relief valve and desiccant change out port; positively driven, non-lubricated 4-way valves interconnecting piping the two adsorbers; micrometer adjustment purge flow valve; field adjustable timer; reactivation indicating lights; control switch; and repressurization valve.

Optional accessories available for these Lectrodryers are pressure gages, color grade humidity indicator, purge flowmeter, heat guards, floor mounting package, molecular sieve desiccant, and a pressure switch interlock to turn off the Lectrodryer in the event that the compressed air is lost to the dryer.

Floor Mounted: Models AIR-9 through AIR-260

The floor mounted type AIR Lectrodryers include adsorber vessels, ASME Code stamped for 150 PSIG with full diameter removable head to provide complete access to the vessel interior. The electric reactivation heaters, which are thoroughly distributed throughout the desiccant bed, provide the best degree of reactivation to secure the optimum capacity of the desiccant. The heaters are

designed with a low watt density for long life, and, in addition, include thermostatic over-temperature protection. Because of their unique design, the reactivation heaters provide no interference with the changeout of desiccant should it ever be required.

Lubricated 4-way plug valves interconnect the two adsorbers with an interlocking valve drive mechanism powered by a pneumatic operator, complete with solenoid controls. Standard accessories include relief valves on each adsorber, locally mounted pressure gages, dial thermometer to measure reactivation exhaust temperatures, calibrated direct reading purge flowmeter with micrometer adjusting valve, purge exhaust muffler, color grade humidity indicator, repressurization valve, and reactivation indicating lights.

All electrical equipment is mounted in a single enclosure for easy accessibility.

Optional features include dial thermometers for each tower, switch failure, heater failure, over-temperature and high humidity detection with alarm contacts. Lectrolod humidity control can be supplied to cycle the Lectrodryer on usage demand, with a resultant saving in utilities that more than pays for itself over an extended period of time.



SIMPLE CONTROL SYSTEMS

The reversing of air flow through the two adsorber towers is done with 4-way valves that are positive in operation. Dependable adjustable timer provides extra flexibility. In the event of power failure, the unit will "fail safe," meaning that the air flow will continue.

WALL MOUNTED TYPE

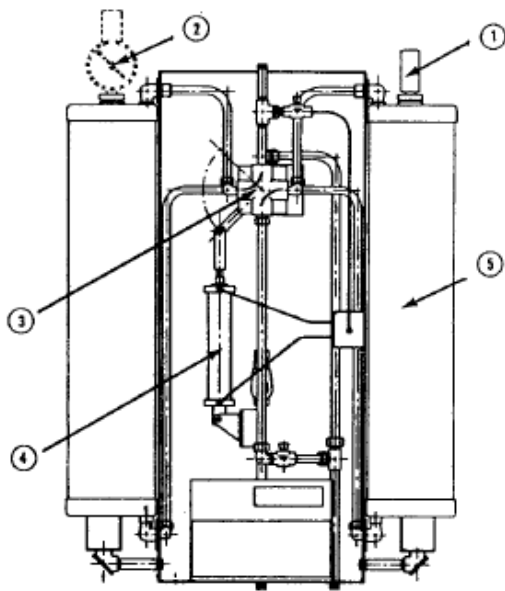

- ① Relief Valve
- ② Pressure Gage (optional)
- ③ 4-way Valve
- ④ Air Cylinder
- ⑤ Adsorber

FLOOR MOUNTED TYPE

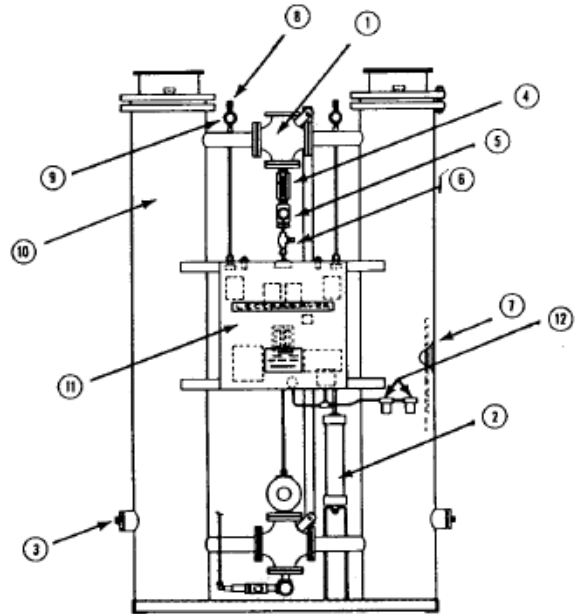

- ① 4-way Valve
- ② Air Cylinder
- ③ Desiccant Drain
- ④ Purge Flowmeter
- ⑤ Color Grade Humidity Indicator
- ⑥ Purge Flow Metering Valve
- ⑦ Heater
- ⑧ Relief Valve
- ⑨ Pressure Gage
- ⑩ Adsorber
- ⑪ Control Panel
- ⑫ Filter-Lubricator

FLOW DIAGRAM TYPE AIR

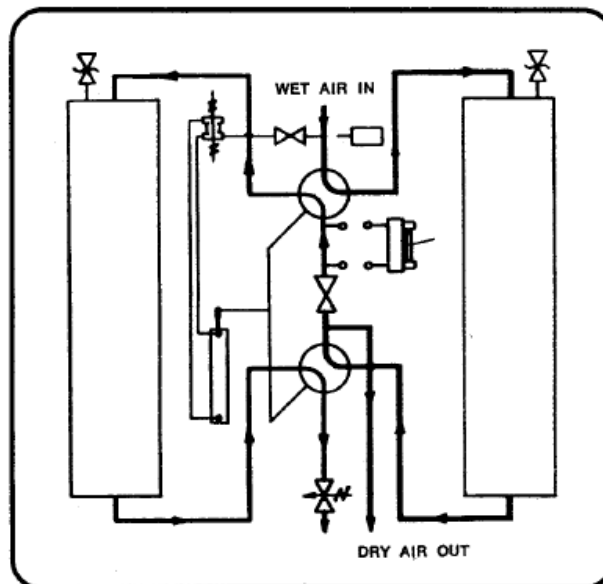

LECTRODRYER HAS THE SOLUTION FOR ALL COMPRESSED AIR AND GAS DRYING PROBLEMS

Lectrodryer offers a complete range of drying and purification equipment:
For atmospheric or high pressure conditions
For very small or very large air volumes
For air, gases, and certain organic fluids

Regenerative Adsorption Dryer

Typical applications:

Drying compressed air for instruments; purging of refrigeration coils, compressors, and systems; drying air for ozone generators; vacuum-breaking operations controlled atmosphere gas



Features:

Carbon steel pressure vessels with ASME Code (where applicable) for up to 150 PSIG Stainless steel perforated metal desiccant support and inlet flow diffuser, sheathed or non sheathed heating element in which each adsorber vessel with thermostatic over temperature protection in the heater bundle, two 4-way lubricated plug valves with air piston operator and solenoid valve controls, thermal pressure relief valves, pressure gages, dial thermometer in the purge outlet, 110 volt controls and NEMA 1 electrical enclosures.

Optional Features:

Special controls and electrical enclosures.

Refrigeration-Type Industrial Gas Dryer

Typical Application:

Low pressure situations for controlling atmospheric gases.

Features:

Power-on light, high temperature warning light, on/off switch, refrigeration analyzer gage, gas-out gage, gas-in temperature gage, low suction pressure cut-out, high head pressure cut-out, hot gas bypass capacity control, start push button pump down shut off cycle, oil pressure control, and suction accumulator.



Optional Features:

Special control and electrical enclosures.

Lube Oil / Air Tanks

Lectrobreather tank vent dryers prevent atmospheric moisture from entering storage during "breathing" due to ambient temperature changes and draining periods. Valuable oils and chemical solutions remain free of water contamination.



Lectrodryer Filters

The Lectrodryer type SF and type F filters provide high efficiency filtration with ten sizes available in each type for flows to 8400 SCFM, larger sizes available on application. Both types have a high level filter efficiency of 99.985% retention (0.015 DOP penetration) for filtration to a 0.3 micron



CONTINUING THE TRADITION OF QUALITY AND SERVICE SINCE 1932

LECTRODRYER

P.O. Box 2500, Richmond, KY 40476-2602 U.S.A.
 Phone: (859) 624-2091 Fax: (859) 623-2436
 Website: www.lectrodryer.com E-mail: info@lectrodryer.com